

THE SEARL EFFECT, By S. Gunnar Sandberg.

In 1946, a basic discovery of a magnetic nature, was made by John R.R. Searl of Wotton, Berkshire. He found, that if a small ac-component ( $\sim 10^2$  mA) of radio frequency ( $\sim 10^7$  Hz) is superimposed on the magnetization direct current (fig. 1) during the manufacturing process of permanent ferrite magnets, they acquire new and unexpected properties.

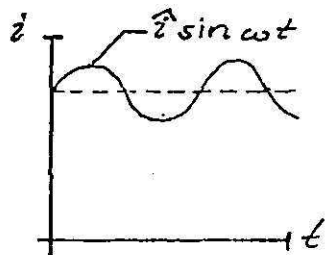

Fig. 1

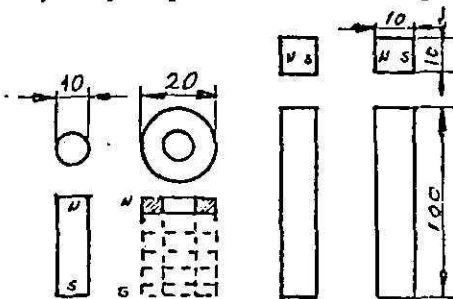
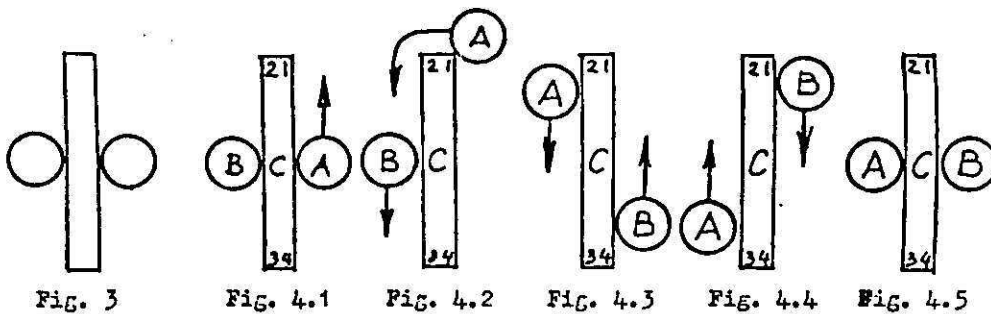

Fig. 2

The first set of permanent magnets made according to the procedure described, consisted of two bars - each about  $100 \times 10 \times 40$  mm - and two rollers. One roller was made in the shape of a cylinder ( $\approx 10$  mm diameter) and the other consisted of a number ( $\sim 5$ ) of annular rings ( $\approx 20$  mm ext. diameter) (fig. 2). All these magnets in the set had been simultaneously magnetized in the described manner.

These permanent magnets are still in existence and was demonstrated to me by Searl on August 15, 1962. If the magnets are put together according to the configuration in fig. 3, they will interact with each other in the following manner (fig. 4). If magnet A is slowly moved by an external force, towards corner 1 of magnet C (fig. 4.1) and carefully pushed around the same corner (fig. 4.2), magnet A will accelerate to a considerable speed, roll around corner 2 and continue its motion along the left hand side of magnet C (fig. 4.3), until it reaches a turning point (fig. 4.4). At the same time as magnet A is pushed around corner 1, magnet B starts moving spontaneously and accelerates to high speed, roll around corners 3 and 4 and continue its motion along the right hand side of magnet C (fig. 4.5), until it reaches a turning point (fig. 4.4). After magnets A and B have reached their respective turning points, they will oscillate synchronously ( $\sim 10$  Hz), until they come to rest in the new position (fig. 4.5) (time constant  $\sim$  seconds).



THE SEARL EFFECT GENERATOR.

The next logical step taken by Searl, was to replace the bar magnets by annular rings, placing the rollers around the outside (fig. 5). According to the information given to me by Searl, the same effect is produced in this configuration as with the straight bars, i.e., if one of the rollers is set in motion by an external force, the other roller starts moving spontaneously in the same direction (fig. 5).

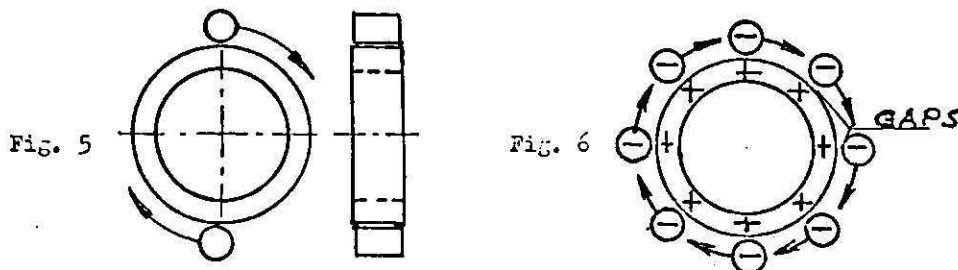

Searl found that if the number of rollers - placed around the outside of the ring - reaches a certain minimum number\* (fig. 6), the rollers are set in motion spontaneously, increasing in speed, until a stationary dynamic state is reached.

He also found that the device, when running, produced an electrostatic potential difference in the radial direction, between ring and rollers. The stationary ring being positively charged and the rollers negatively charged (fig. 6). Gaps, created by magnetic interaction and centrifugal force, prevented mechanical and galvanic contact between ring and rollers (fig. 6).

By adding stationary C - shaped electromagnets to the stationary ring and the moving rollers (fig. 7), the device produced electric power of its own ( $\sim 10^2$  watts). Several small generators of this type were manufactured and by 1952 Searl had built the first multi-ring generator.

\* This minimum number depends on geometry and material parameters, and is not known to me at the time of writing this report.

12

This device was about three feet in diameter and consisted of three segmented rings in the same plane, with a number of electromagnets at its periphery. (fig 8). Each ring consisted of a number of magnetic segments with insulating spacers between each such magnet (fig. 9). Due to high cost, this generator did not contain enough magnets to be self starting.

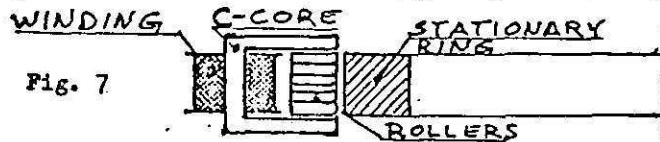

Fig. 7



Fig. 8

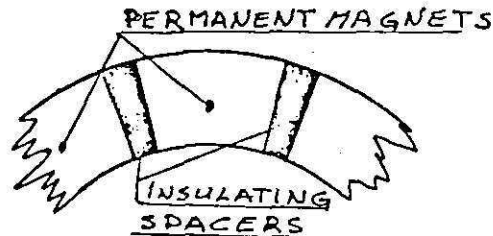

Fig. 9

The generator was tested in the open and the armature was set in motion by a small engine. The device produced an unexpectedly high electrostatic potential in the radial direction. At relatively low armature speeds, a potential of the order of 1 000,000 volts was produced, as indicated by static effects on near objects. Characteristic crackling and the smell of ozone supported the conclusion.

The unexpected then occurred. The generator lifted while still speeding up, broke the union between itself and the engine, and rose to an altitude of about 50 feet. Here it stayed for awhile, still speeding up, and surrounded itself in a pink halo. This indicated ionization of the air at a much reduced pressure. Another interesting side effect caused local radio receivers to go on of their own accord. This could have been due to ionizing discharge or electromagnetic induction. Finally, the whole generator accelerated at a fantastic rate and is believed to have gone off in to space.

Since 1952, Searl and his co-workers have manufactured and tested more than ten generators, the largest being a 10 metre disc-shaped craft.

Searl's work has never been published in the scientific or the technical literature, but many individuals and institutions know of his findings.

However, a theory has been put forward by Professor S. Seike<sup>1</sup> in an attempt to explain the interactions taking place in and around the generator. A patent was applied for by Searl, but later withdrawn.

Mr. Searl would like co-operation and has given me some important information concerning the principles of the manufacturing process, this is detailed below.

1. During magnetization a small ac-component ( $\sim 10^2$  mA) of radio-frequency ( $\sim 10^7$  Hz) is superimposed on the magnetization direct current.
2. At least 180 amperturns are needed for magnetization.
3. For normal running, all magnets in the same generator must be simultaneously magnetized.
4. The specially made magnets have a tendency of temporarily changing their characteristic properties when in contact with other permanent magnets, or magnets magnetized with ac-components of different frequencies. However, after being removed from external disturbing fields, the special magnets will, after a few minutes, regain their original properties. This phenomenon could be used as a control mechanism.
5. Searl has pointed out that it is possible to program the behaviour of the generator by magnetizing just one of the small annular rings with a different frequency. He has, for instance, been able to make the generator temperature dependent in such a way that it will stop running if the temperature exceeds a certain level ( $\sim 50$  °C); a value far below the Curie Temperature.
6. Basically, the internal magnetic field is along the axis of the rollers and annulus (Fig. 10).

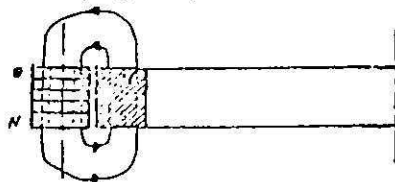
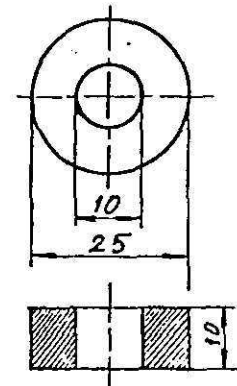
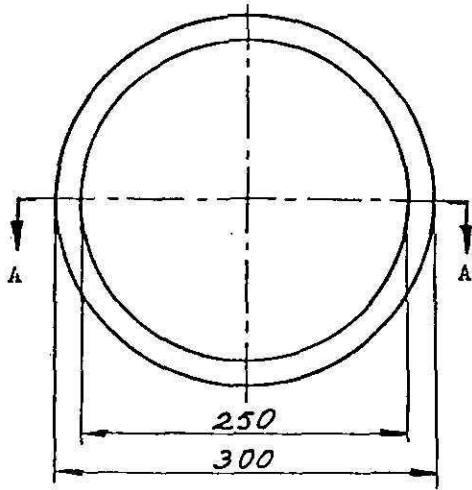

Fig. 10

7. Magnetic materials: Ferrites or magnetic ceramics.
8. Measurements made by Searl show that the power to mass ratio from the "one-ring" generator is 180 Kw/ton when interacting with the gravitational field of the earth.
- 9) Seike, Shinichi, The Principles Of Ultra Relativity, National Space Research Consortium, 4, No. 12, 1 Chome, Chiyodoh, Utsunomiya City, Saitama Prefecture (796), Japan, 1970.

Searl has proposed construction of an "one-ring" generator with the following dimensions:



Annular ring.

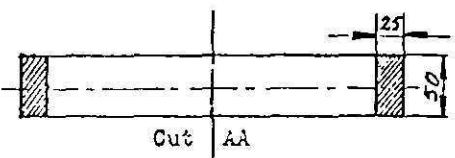

Stationary annular ring.  
Material: Magnetic ceramics  
Magnetization current: ac-component  
40 kHz or 80 kHz.

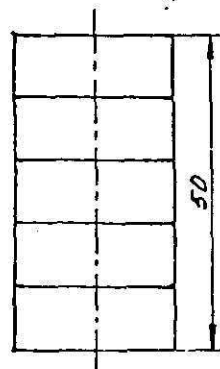

Stacked annular rings.

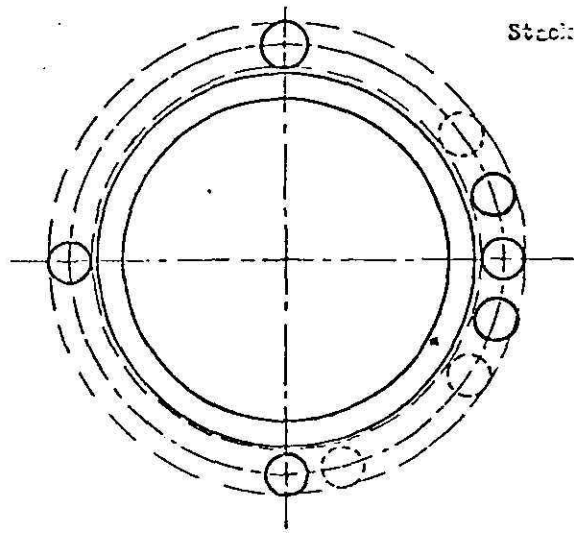

The concepts "THE SEARL EFFECT" and "THE SEARL EFFECT GENERATOR" have been suggested by Peter Barret, B. Sc., an assistant to John R.R. Searl.

University of Sussex

October 11, 1982

*S. Gunnar Sandberg*

S. Gunnar Sandberg.

# SCHOOL OF ENGINEERING & APPLIED SCIENCES

UNIVERSITY OF SUSSEX



Report No. SEG-002

THE SEARL-EFFECT GENERATOR

Design and Manufacturing  
Procedure

The contents of this document are confidential  
and must not be disclosed to third parties.

*S. Gunnar Sandberg*

S. Gunnar Sandberg  
School of Engineering &  
Applied Sciences,  
University of Sussex.

## The Searl-Effect Generator

### Design and Manufacturing Procedure

The objective of this report is to reconstruct the experimental work carried out between 1946 and 1956 by John R. R. Searl that concerns the geometry, materials used, and the manufacturing process of the Searl-Effect Generator (SEG).

The information given here is based on personal communication between the author and Searl and should be considered preliminary as further research and development may give reason to alter and/or update the content.

#### The Gyro-Cell

The SEG consists of a basic drive unit called the Gyro-Cell (GC) and, depending on the application, is either fitted with coils for generation of electricity or with a shaft for transfer of mechanical power. The GC can also be used as a high voltage source. Another and important quality of the GC is its ability to levitate.

The GC can be considered as an electric motor entirely consisting of permanent magnets in the shape of cylindrical bars and annular rings.

Fig. 1 shows the basic GC in its simplest form, consisting of one stationary annular ring-shaped magnet, called the plate, and a number of moving cylinder-shaped rods called runners.

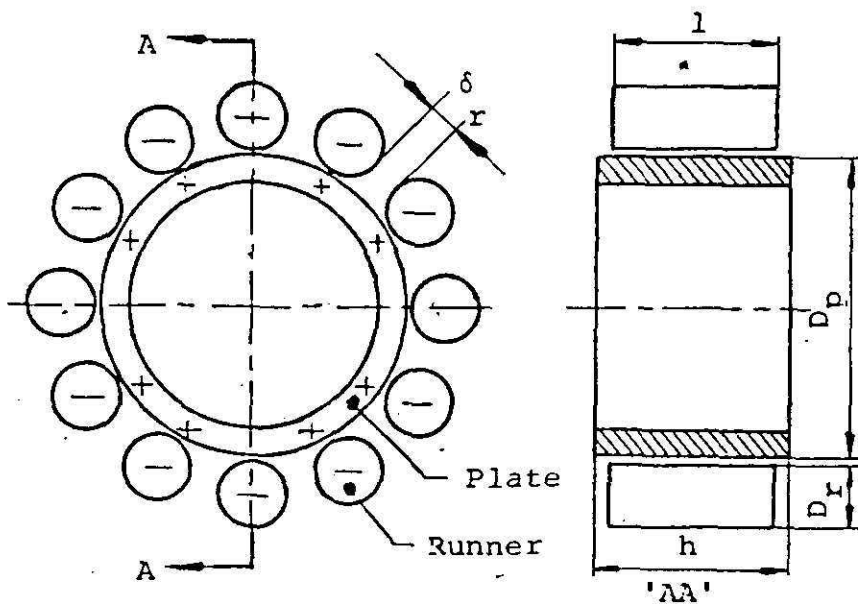

Figure One

During operation each runner is spinning about its axis and is simultaneously orbiting the plate in such a manner that a fixed point p on the curved runner surface traces out a whole number of cycloids during one revolution round the plate, as shown by the dotted lines in fig. 2.

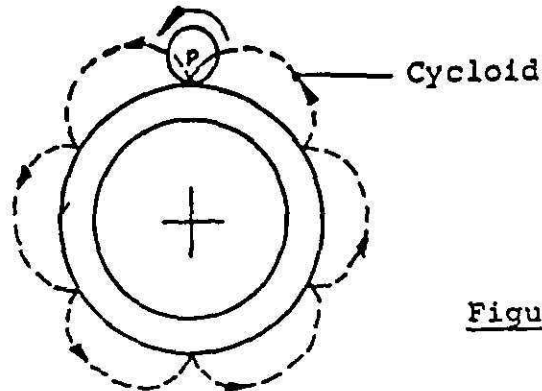

Figure two

Measurements have revealed that an electric potential difference is produced in the radial direction between plate and runners; the plate being positively charged and the runners negatively charged, as shown in fig. 1.

In principle, no mechanical constraints are needed to keep the GC together since the runners are electromagnetically coupled to the plate. However, used as a torque producing device, shaft and casing must be fitted to transfer the power produced. Furthermore, in applications where the generator is mounted inside a framework, the runners should be made shorter than the height of the plate to prevent the runners from catching the frame or other parts.

When in operation, gaps are created by electromagnetic interaction and centrifugal forces preventing mechanical and galvanic contact between plate and runners and thereby reducing the friction to negligible values.

The experiments showed that the power output increases as the number of runners increase and to achieve smooth and even operation the ratio between external plate diameter  $D_p$  and runner diameter  $D_r$  should be a positive integer greater than or equal to 12. Thus

$$\frac{D_p}{D_r} = N > 12 \quad (N = 12, 13, 14, \dots) \quad (1)$$

The experiments also indicated that the gaps  $\delta_r$  between adjacent runners should be one runner diameter  $D_r$  as shown in fig. 1.

More complex Curo-Cells can be formed by adding further

plate GC consisting of three sections, A, B and C. Each section consists of one plate with corresponding runners.

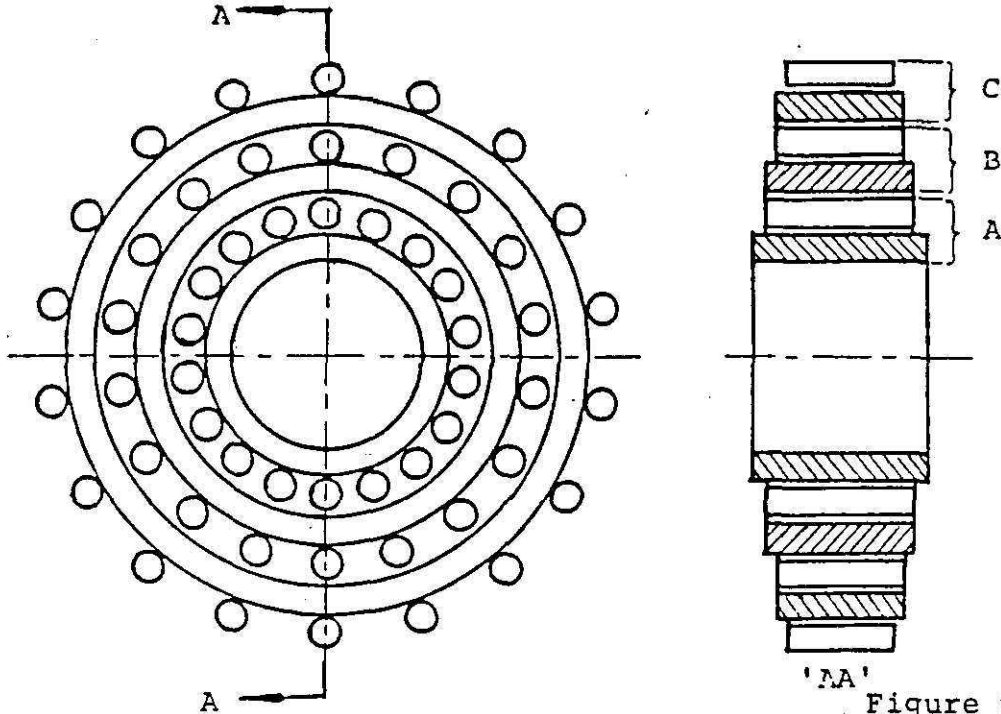

Figure three

The experiments showed that for stable and smooth operation all sections should be of equal weight. Thus

$$W_A = W_B = W_C \quad (2)$$

where

$W_A$  = weight of section A,

$W_B$  = weight of section B,

and  $W_C$  = weight of section C.

#### The Magnetic Field Configuration

Due to a combined DC and AC magnetising process, each magnet acquires a specific magnetic pole pattern recorded on two tracks consisting of a number of individual north-poles and south-poles, as illustrated in fig. 4.

Magnetic measurements have revealed that the poles are approximately one millimetre across and evenly spaced. It was also found that the pole density  $\delta$  - defined as the total number of poles  $N$  per track divided by the circumference,  $\pi D$  - must be a constant factor specific for a particular generator. Thus

$$\delta = \frac{N}{\pi D} = \frac{N_r}{\pi D} = \text{constant} \quad (3)$$

where  $N_p$  is the total number of poles per track on plate and  $N_r$  is the total number of poles per track on runner.

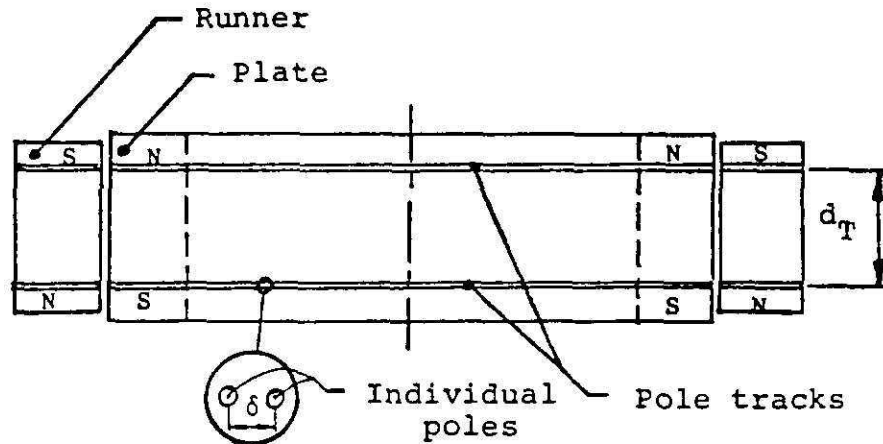

Figure four

Furthermore, the distance  $d_T$  between the two pole tracks must be the same for all runners and plates which are parts of the same GC.

The pole tracks allow automatic commutation to take place and create a turning moment. Exactly how this is achieved is not understood and will require further research efforts. Likewise, the source of energy is at present unknown. Further research is also needed to establish the exact mathematical relationship between output power, speed, geometry and material properties, such as mass density and electromagnetic properties of the materials used.

#### Magnetic Materials

The magnets used in the original experiments were made of a mixture of two types of ferromagnetic powders imported from the USA. One of these magnets, still in existence, has been qualitatively analysed and was found to contain the following elements:

1. Aluminium (Al)
2. Silicon (Si)
3. Sulphur (S)
4. Titanium (Ti)
5. Neodymium (Nd)
6. Iron (Fe).

The spectrogram is illustrated in fig. 5.

- 5 -

Al Si	Ti Nd	Fe
— S —	— —	— —

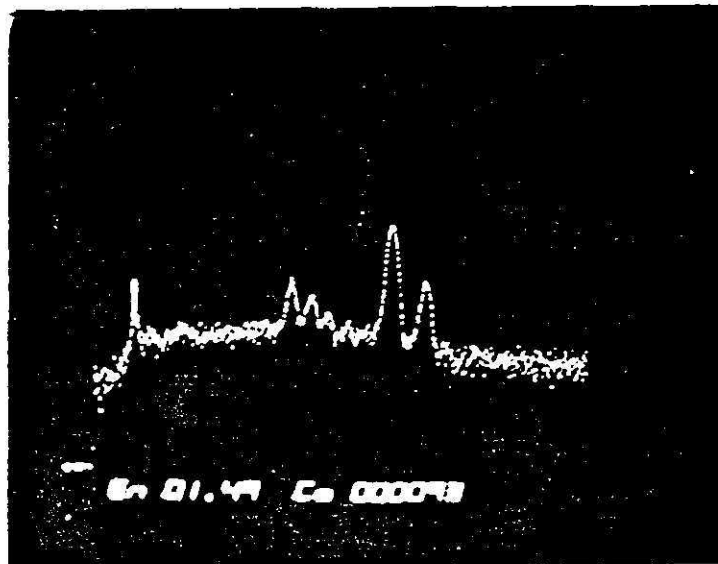

Figure five

The Induction Coils

If the SEG is used as an electric power plant a number of induction coils must be fitted to the GC. The coils consist of C-shaped cores made of soft steel (Swedish steel) or high  $\mu$ -material ( $\mu$ -metal). The number of turns and wire gauge used depends on the application. Fig. 6 shows the basic design.

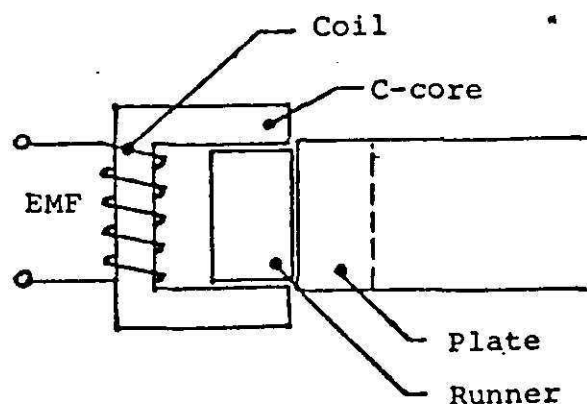

Figure six

Manufacturing Procedure

The block diagram in fig. 7 illustrates the main stages in the manufacturing process.

Stage 1 Magnetic materials and bonding agents

magnetic raw materials to be cheaper and/or more efficient than the ones used in the original experiments. It is also possible that other types of binder may improve the performance.

Stage 2 Weighing

In general, to produce efficient magnets the right amount of each element contained in the ferromagnetic powder is crucial. It is therefore reasonable to suggest that when mixing different types of powders an optimal weight ratio does exist that will produce a 'best' magnet.

At present, however, this weight ratio is not known for the powders used by Searl in his past experiments. Together with new magnetic materials and optimisation of generator geometry, this is an area in which research efforts could be profitable.

In general, the amount of binder used should be as small as possible to achieve maximum mass density of bonded magnets. However, the possibility that the binder is taking an active part in the generation of the Searl-Effect must not be excluded. For instance, the dielectric properties of the binder may play an active role in the electromagnetic interactions taking place in the SEG. If that is the case, then a further amount of bonding material may be beneficial.

Stage 3 Mixing

The mixing is an important process which will decide the homogeneity and reliability of the finished product. A homogeneous mixture can be achieved by using turbulent air flow inside the mixing container.

The experiments did show that an improved performance was achieved if all magnets for the same generator were made from the same batch.

Stage 4 Moulding

During the moulding process the compound - consisting of ferromagnetic powders and thermoplastic binder - is compressed and simultaneously cured by heating. Fig. 8 illustrates the tool used for making 'blinds'. A 'blind' is an unmagnetized runner or plate/part of plate. When manufacturing large plates ( $D_p > 30$  cm) it may be necessary to make them in segments rather than in one piece.

Manufacturing Process

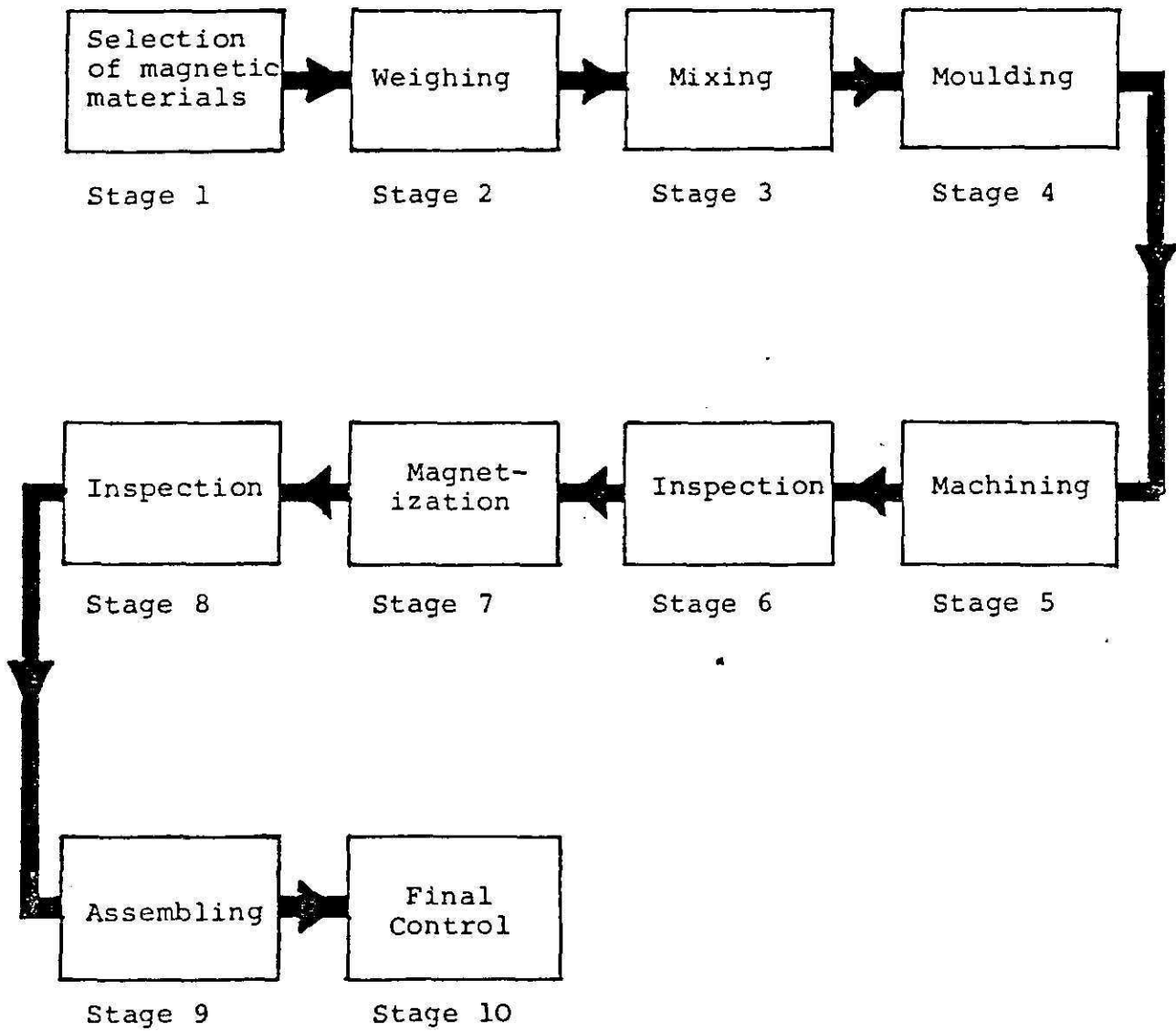

Figure seven

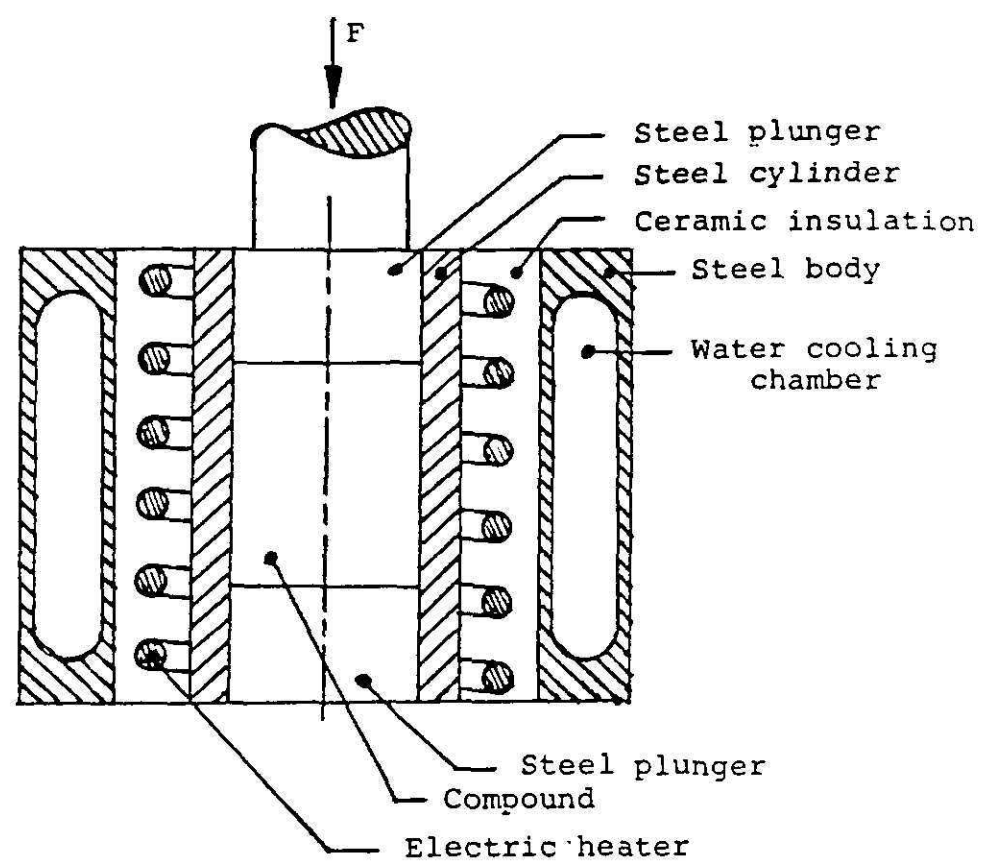

Figure eight

The figures given below should be considered as guide lines only, since correct data are not available regarding the influence of the moulding process on the Searl-Effect.

1. Pressure: 200-400 bars
2. Temperature: 150°C-200°C
3. Compression time: > 20 minutes.

Before releasing the pressure the mould must be allowed to cool.

Stage 5 Machining

This process can be bypassed if the weighing and moulding procedures are carried out correctly. However, it may be necessary to polish the cylindrical surface of runners and plates.

Stage 6 Inspection

Control of dimensions and surface finish.

Stage 7 Magnetization

Runners and plates are individually magnetized in a combined dc-field and ac-field during one on-off duty cycle. Fig. 9 illustrates the magnetizing circuit.

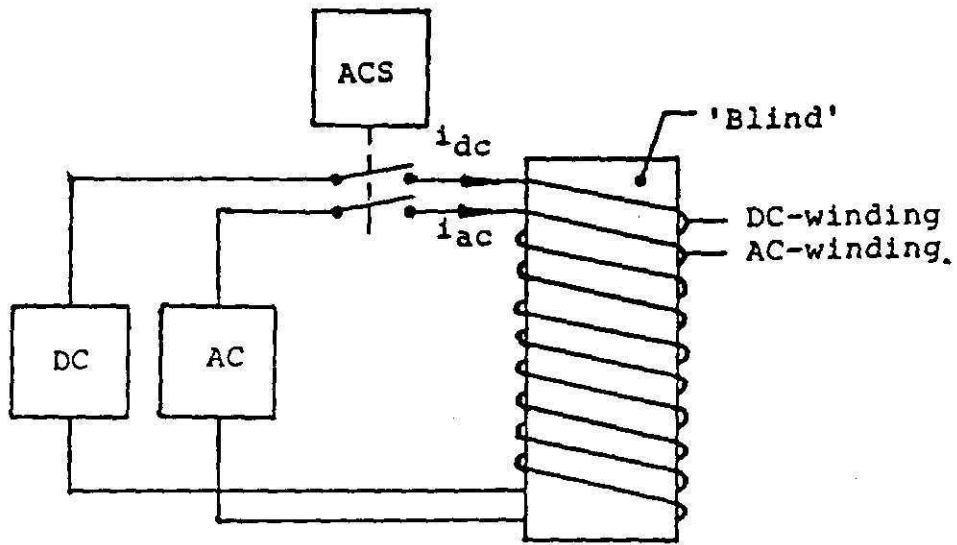

Figure nine

The function of the automatic control switch (ACS) is to simultaneously switch on the dc-current,  $i_{dc}$  and the ac-current,  $i_{ac}$  at such a time,  $t = t_{on}$ , that the instantaneous value of the total magnetomotive force (MMF) is always positive. Thus

$$MMF = i_{dc}N_1 + i_{ac}N_2 > 0$$

where  $N_1$  is the number of turns in the dc-winding and  $N_2$  is the number of turns in the ac-winding.

Fig. 10 shows the total MMF as a function of time.

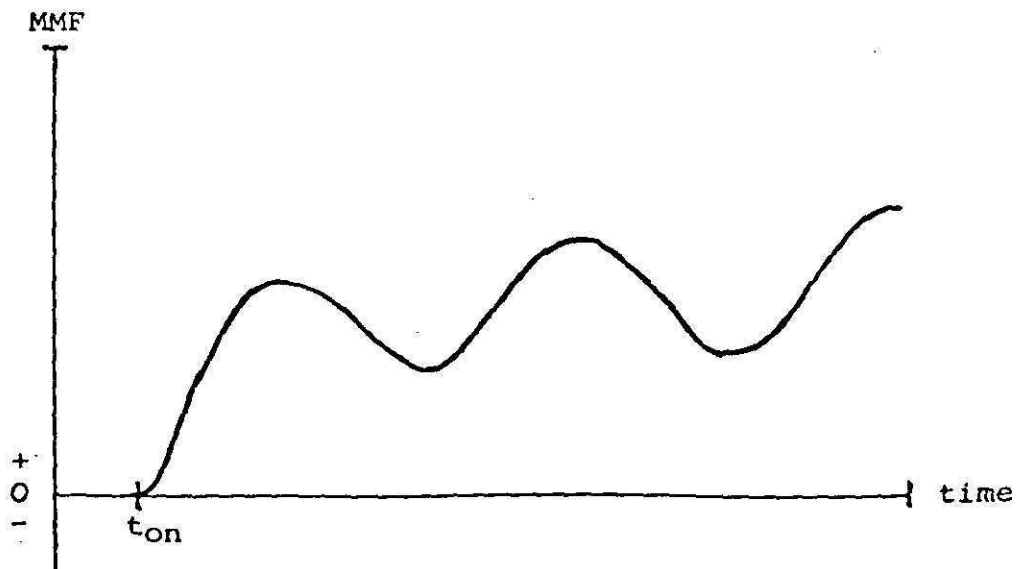

The magnetization coil consists of a dc-winding containing approximately 200 turns of heavy copper wire and an ac-winding containing approximately 10 turns of copper strip wound on top of the dc-winding. Fig. 11 shows a cross section of the coil and its dimensions.

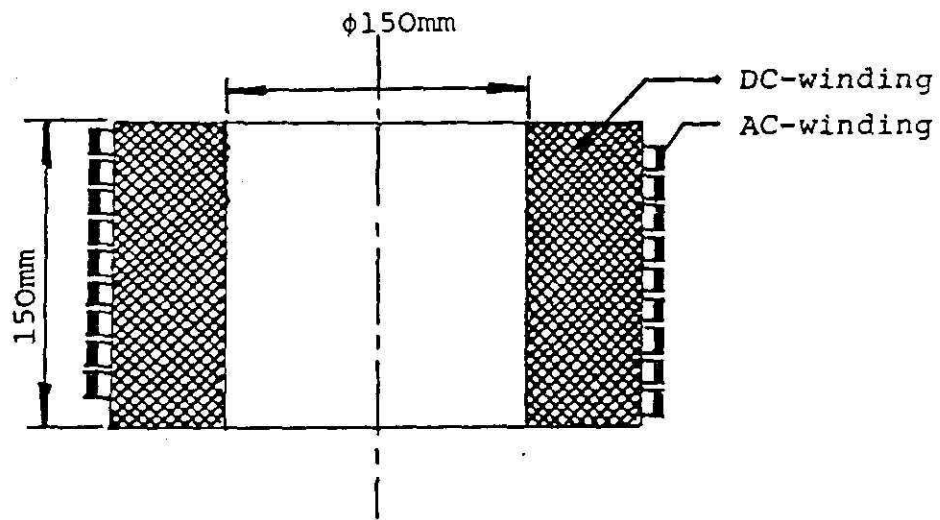

Figure eleven

Recommended parameter values:

dc-current,  $i_{dc} = 150\text{A to }180\text{A}$

ac-current,  $i_{ac} = \text{unknown}$

frequency,  $f = 1 - 3 \text{ MHz.}$

Stage 8 Inspection

The purpose of this control is to test for the existence of and the correct spacing of the two pole tracks. The measurements can be made with a magnetic flux density meter in combination with a set of control magnets.

Stage 9 Assembling

The assembling procedure depends on the application. Used as a mechanical drive unit the magnets must be mounted inside a framework and fitted to a drive shaft. Used as an electric power plant, induction coils must be fitted to the framework.

Equipment used by Searl

Hand-press No data available. Used for making plastic bonded blinds.

Magnetising equipment

DC-coil Consisted of approximately 200 turns of insulated heavy cooker wire. The coil had been used for degaussing turbine and generator shafts.

AC-coil Consisted of 5 to 10 turns of copper wire wound on top of DC-coil.

DC-switch Hand operated.

AC-switch Hand operated.

The two switches were connected together mechanically and operated simultaneously.

DC-source Westinghouse 415V, 3-phase 50Hz mercury rectifier, o/p 180A, voltage unknown.

AC-source Marconi Signal Generator type TF867, o/p 0.4 $\mu$ V-4V, Z = 75 $\Omega$ , o/p from 2-4V.

THE SEARL-EFFECT GENERATOR

Research Programme

The following research proposals should be considered preliminary and may be subject to alterations.

The objectives of long-term research efforts should be threefold:

- A. To experimentally confirm the existence of the claimed effects and interactions of the Searl-Effect Generator (SEG), as stated by J. R. R. Searl. This work should be based on the knowledge gained from the experimental work carried out by Searl during the period from 1946 to 1956<sup>1</sup>, and should proceed according to the following plan:-
- (1) To undertake design and construction of tools and equipment necessary to manufacture the SEG. This will include making:-
    - (a) moulding equipment for production of plastic bonded magnets;
    - (b) magnetiser, consisting of DC- and AC-coils, control switches and power supplies.
    - (c) measuring equipment and instruments for test and control (Hall-effect probes, magneto meters, ammeters etc.).
  - (2) To undertake manufacture of runners and plates. (The definitions of these concepts are given in the report SEG-002, June 1985).
  - (3) To undertake a detailed study of the magnetisation process used in the manufacturing procedure of the GC in order to confirm the existence of and establish the nature of the magnetic pole pattern 'recorded' onto runners and plates.
  - (4) To undertake the manufacture of the Gyro-Cell (GC).
  - (5) To undertake a detailed study of the GC in order to confirm the existence of and nature of interacting forces and fields between runners and plates.
  - (6) To undertake a detailed study of the GC in order to confirm the existence of and establish the nature of interacting forces and fields between the GC and

the environment, such as the planetary gravity field, the earth's electromagnetic fields, the atmosphere and other material bodies, etc.

(7) To undertake a detailed study of the SEG in order to establish the nature of the energy source(s).

- B. To undertake a quantitative and qualitative study of the SEG in order to establish mathematical relationships (Field equations, equations of motion and constitutive equations) between generated fields and interactions on one hand and geometry, material properties and energy source(s) on the other hand, i.e.

$$\left[ \begin{array}{l} \text{Generated Fields} \\ \text{and Interactions} \end{array} \right] = \left[ \begin{array}{l} \text{Coupling} \\ \text{Coefficients} \end{array} \right] \times \left[ \begin{array}{l} \text{Generator of} \\ \text{Fields and} \\ \text{Interactions:} \\ \text{Energy Source(s)} \end{array} \right]$$

Short-term research efforts should concentrate on finding empirical relationships based on measurements and observations in order to derive constitutive equations and to gain a deeper understanding of the physical principles involved. Only then will it be possible to derive correct field equations describing the physical interactions within and around the SEG as described under point A. This work will serve as a basis for optimisation procedures.

- C. To undertake a detailed study of experimental results and mathematical relations in order to optimise design solutions with respect to maximum efficiency and economy and/or specific properties depending on application.

(march 1986  
SEG-004)

Additional Information Regarding  
the manufacture of the Searl-  
Effect Generator.

1. According to the information given by Searl the plastic binder, used in the manufacturing process of the plastic bonded magnets, should have an excess of negative charge (negative ions / electrons). I have not yet studied the electrical properties of polymers in detail and can therefore not give a qualified statement regarding the selection of plastic binder and its importance for the effect.

\* in later experiments,

The plastic used by Searl\* was supplied by a company in Kewbury, Berkshire, England. However, the bonding agent used by Searl in his original experiments between 1946 and 1952 was supplied by an American company who also supplied the aluminium-titanium based ferro-magnetic powder. It would be desirable to use the same kind of binder and magnetic powder in order to exactly repeat Searl's original experiments. According to Searl, the American supplier can be found in the American trade catalogue "The Thomas Register". Searl's documents were all destroyed in a fire in 1983, but he states that if shown

the appropriate pages in the catalogue he will be able to identify the company if it is still in existence.

2

The importance of the position of the 'blind' inside the coils during magnetisation is unknown.

However, in the initial experiments it is advisable to place and clamp the blind in the centre of the coils, as shown in figure 1.

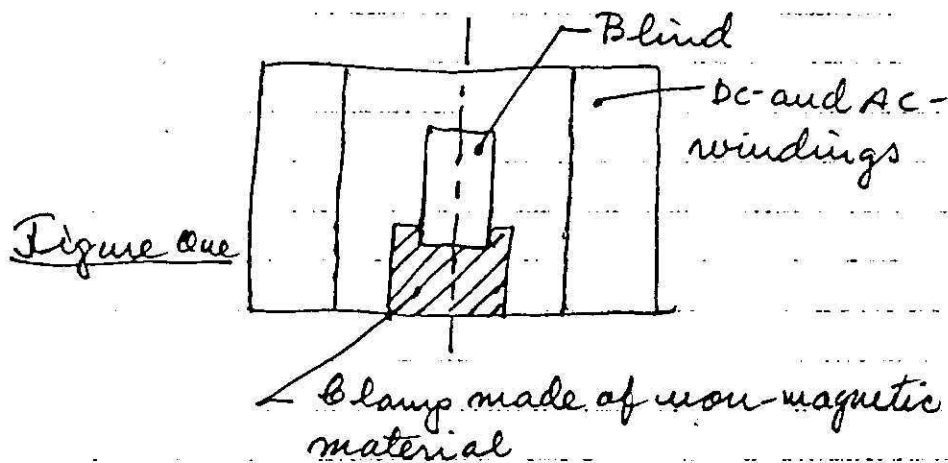
3

\* 7

The GC will only function properly if the AC-voltage across the AC-winding is maintained at a constant RMS-value\* and at a constant frequency ( $\geq 1$  MHz, sine wave) during the magnetising process of all the magnets (runners and plates) which constitute one and the same Gyro-Cell. The reason for this condition could be due to a possible

\* 7

relationships between frequency and pole density  $\delta$  (Report SEG-002 page 3). <sup>eyes</sup>

4. The GC will function properly if the DC-voltage across the DC-coil is maintained at a constant value\* ( $V = R_{DC-coil} I_m$ ) during the magnetizing process of all the magnets (runners and plates/part of plates) which constitute one and the same gyro-Cell. The reason for this condition is ~~unknown~~ at present unknown

5 The time needed for magnetization is normally very short (in the order of  $\mu$ -seconds and less). However, due to unknown factors, this time may have to be extended to time intervals in the order of seconds.

6 Each magnet (blind) is magnetised during one on-off duty cycle. Seal's statement that the DC-voltage and the AC-voltage should be switched on simultaneously at a zero-crossing of the AC-voltage is based on incomplete experimental

\* ( $V = R_{DC-coil} I_m$ ). The number of amp turns used by Seal in his original experiments was  $I_m N_{oc} = 180 \text{ amperes} \times 180 \text{ turns} = 32400 \text{ At}$ .

~~evidence due to the use of very simple and primitive switching equipment.~~

As the key to success appears to depend on correct switching time it is necessary to design and use more sophisticated electronic switching that will enable the control of the precise timing of the magnetising on-off duty cycle.

7

The existence of the pole-pattern created on each runner and plate, by the combined AC-DC field, was experimentally discovered by magnetic measurements. By scanning the recorded pole tracks using small probes (Hall-effect elements) and a cathode ray oscilloscope, each individual pole was made visible on the oscilloscope screen as shown in fig. 2.

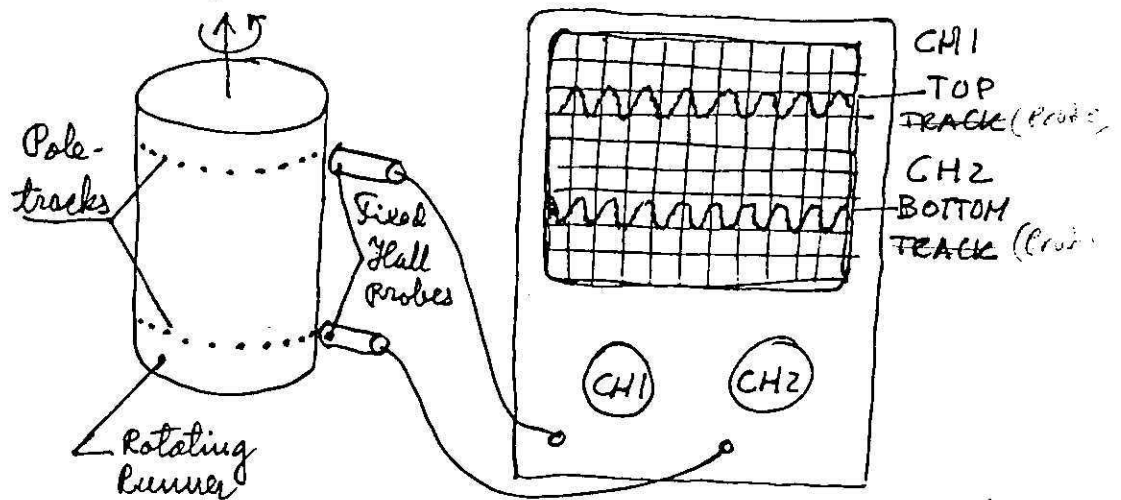

Figure Two.

A more detailed examination of the oscilloscope picture seemed to show that the top track consisted of, for instance, north-poles only and the bottom track of south poles only as illustrated in Figure 3.

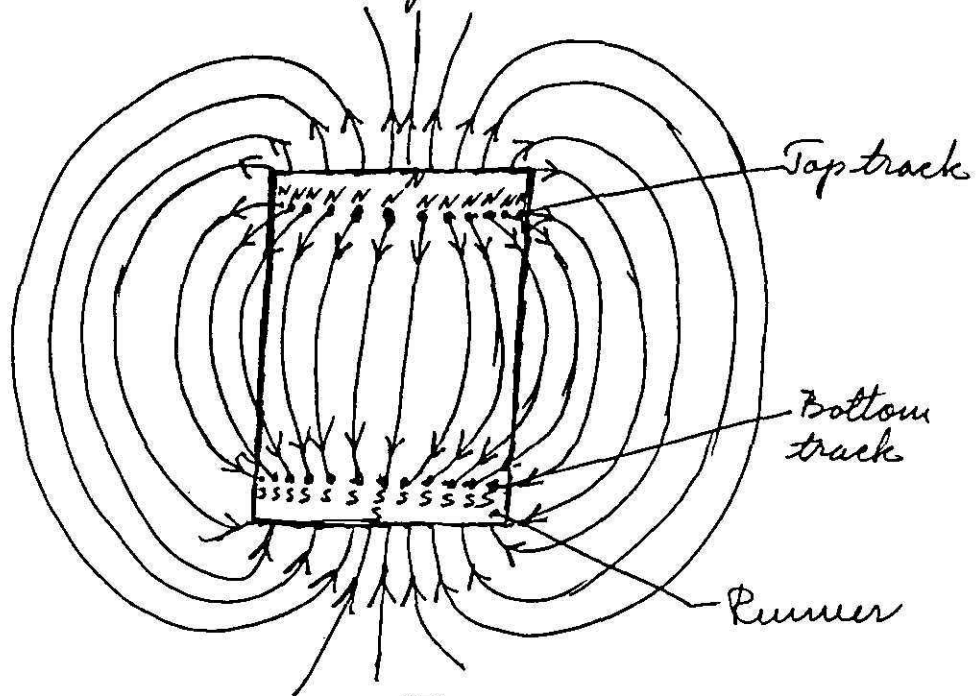

Figure Three.

This field configuration, if it is correct, suggests that the diameter/length ratio of the magnetising coil could be of crucial importance for the manifestation of the Searl-effect. I therefore propose that a number of magnetising coils with different diameter/length ratios are manufactured, e.g.

$D_{\text{coil}}$ (mm)	$L$ (mm)	IN (At)
100	100	32400
100	150	"
150	100	"
150	150	"

12 June 1986 1.

Claim made by John R. R. Searl on  
15 August 1982 at a personal meeting  
between Searl and S. G. Sandberg.  
1952-02 1956.

The radioactive radiation ( $\beta$ ) emitted  
from a sample of strontium 90 ( $^{90}_{38}\text{Sr}$ )  
was measured with a Geiger counter  
before and after the sample was passed  
through the ring of the SEG as  
shown in figure 1.

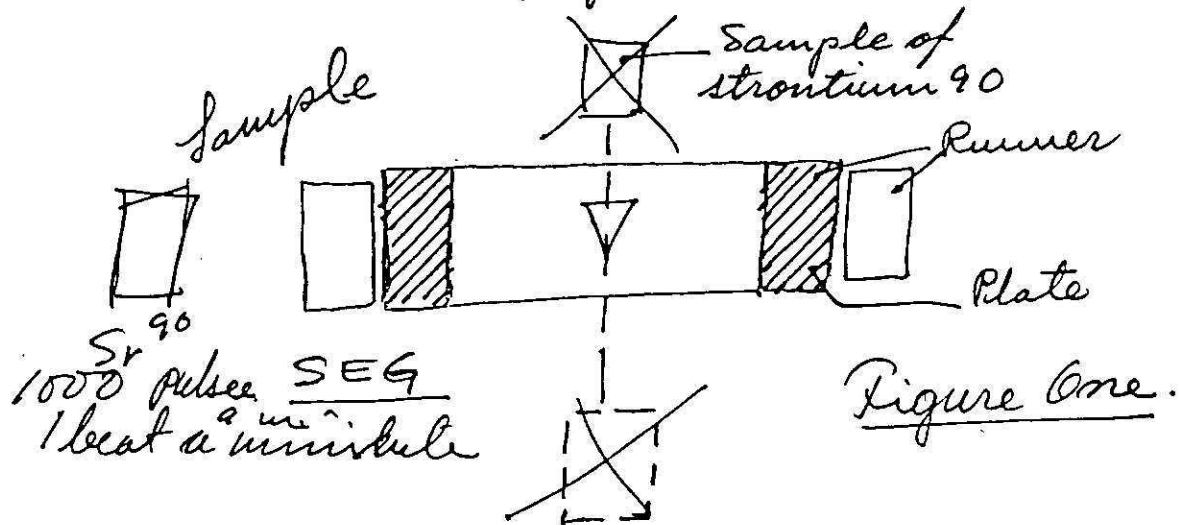

A significant difference in the two  
readings was recorded. The sample  
of  $^{90}_{38}\text{Sr}$  and the Geiger-counter  
were supplied by a scientist.

S. G. Sandberg

M/L17.

Blue pattern

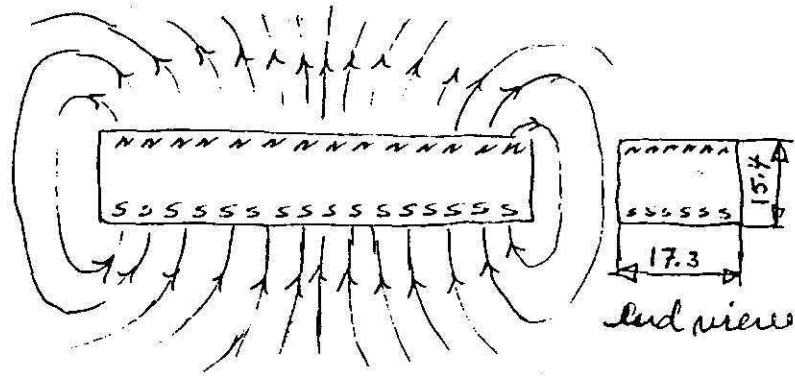

The bar magnet

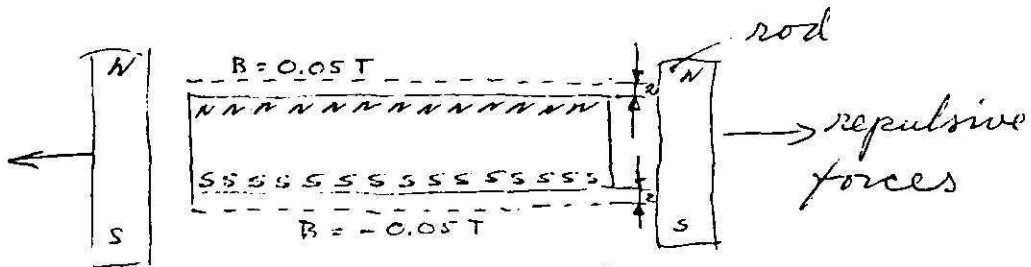

Repulsive mode

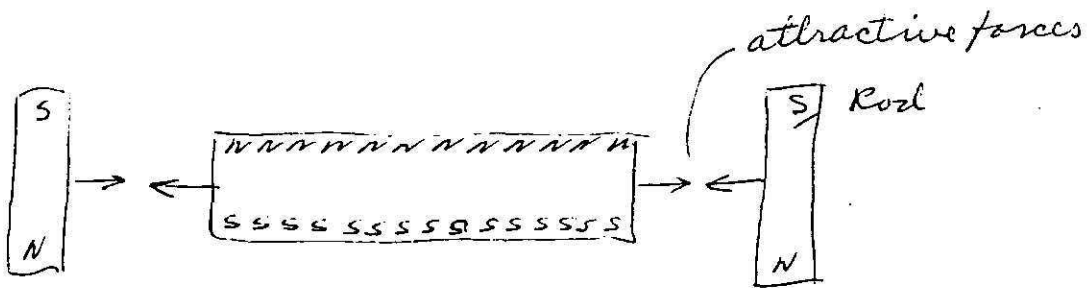

attractive mode

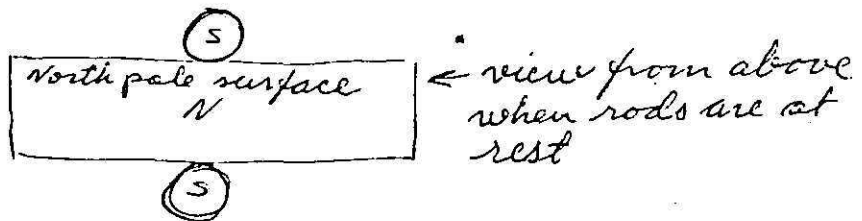

An Analysis of The Resultant Magnetizing Field generated By Superimposing an Alternating Current and an Exponentially Increasing Direct Current In a Coil With Two Windings.

General Considerations.

The coil consists of two windings. Winding 1 carrying the dc-current and winding 2 carrying the ac-current, see fig. 1.

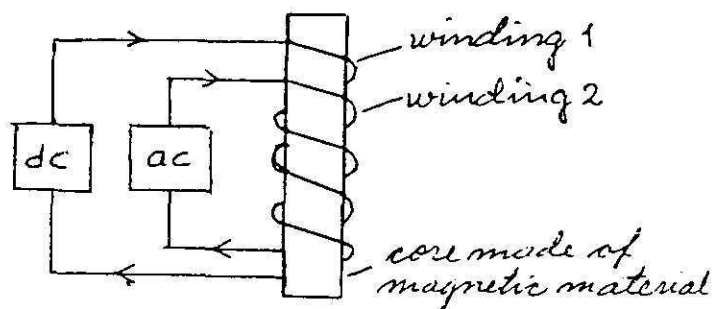

Fig. 1

- $N_1 =$  Number of turns in winding 1 (t)
- $N_2 =$  Number of turns in winding 2 (t)
- $R_1 =$  Resistance in winding 1 (ohms) ( $\Omega$ )
- $R_2 =$  Resistance in winding 2 (ohms) ( $\Omega$ )
- $L_1 =$  Inductance in winding 1 (Henrys) (H)
- $L_2 =$  Inductance in winding 2 (Henrys) (H)
- $U_{dc} =$  DC-voltage (Volts) (Potential difference) (V)
- $U_{ac} =$  AC-voltage (Volts) (Potential difference) (V)
- $i_{dc} =$  Instantaneous value of dc-current (amperes) (A)
- $i_{ac} =$  Instantaneous value of ac-current (amperes) (A)
- $t =$  time (seconds) (s)
- $f =$  Frequency of the AC-voltage (Hertz) (Hz OR C/S)
- $T =$  Periodic time (seconds) (s)
- $\omega =$  angular velocity (Radians/second) (Rad/s)
- $\mathcal{H} =$  magnetizing field (amperes/meter) (A/m)
- $B =$  magnetic induction (Weber/meter<sup>2</sup>) ( $Wb/m^2$ )
- $\mu =$  magnetic permeability (Henrys/metre) (H/m)
- $IN =$  magnetomotive force (ampere-turns) (At)

We neglect the mutual inductance  $M$  and the capacitance of the windings.

The equation describing the resultant magnetizing field  $H_{res.}$  is found by first solving the differential equations governing the currents in the coil.

The DC-circuit, (Fig. 2).

At the time  $t = t_{on}$  a voltage  $U_{dc} = \text{constant}$ , see fig. 2, is supplied to winding 1 and the instantaneous current  $i_{dc}$  is governed by the differential equation

$$\frac{di_{dc}}{dt} + \frac{R_1}{L_1} i_{dc} = \frac{U_{dc}}{L_1} \dots \dots \dots (1)$$

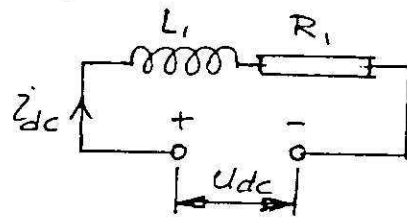
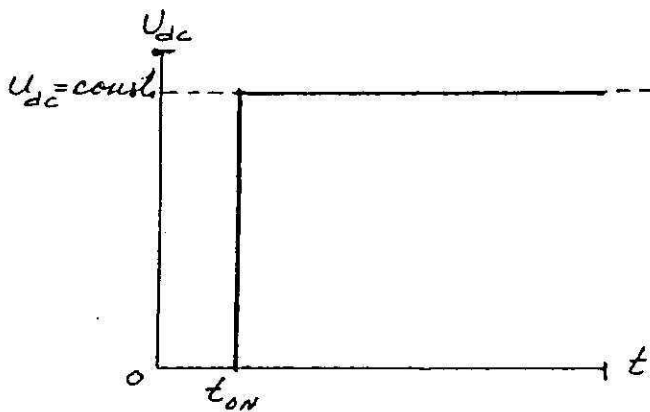

Fig. 2

The solution of the diff. equation 1 is the well known exponential increase of the current  $i_{dc}$  from the time  $t = t_{on}$ , see fig. 3, and equation 2.

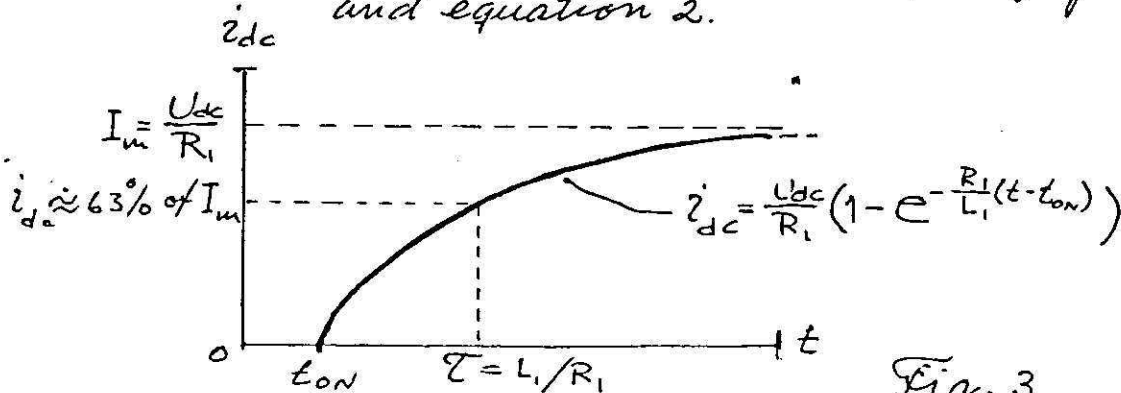

Fig. 3

$$i_{dc} = \frac{U_{dc}}{R_1} (1 - e^{-\frac{R_1}{L_1}(t-t_{on})}) \dots \dots \dots (2)$$

The ac-circuit.

at the time  $t = t_{on}$  a voltage  $U_{ac} = \hat{U} \sin \omega t$  is applied to winding 2, see fig. 4. In this case the instantaneous current  $i_{ac}$  is governed by the differential equation

$$\frac{di_{ac}}{dt} + \frac{R_2}{L_2} i_{ac} = \frac{\hat{U}}{L_2} \sin \omega t \dots \dots \dots (3)$$

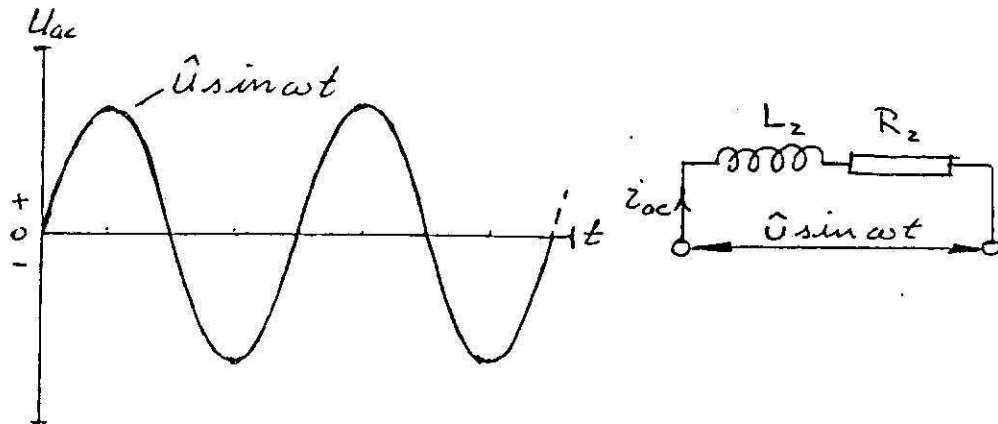

Fig. 4

The solution of differential equation (3) is a sum of a transient current, here

$$- \frac{\hat{U}}{\sqrt{R_2^2 + \omega^2 L_2^2}} e^{-\frac{R_2}{L_2}(t-t_{on})} \sin(\omega t_{on} - \arctan \frac{\omega L_2}{R_2}) \dots \dots (4)$$

see fig. 5, and a steady state current

$$\frac{\hat{U}}{\sqrt{R_2^2 + \omega^2 L_2^2}} \sin(\omega t - \arctan \frac{\omega L_2}{R_2}) \dots \dots \dots (4a)$$

see fig. 6

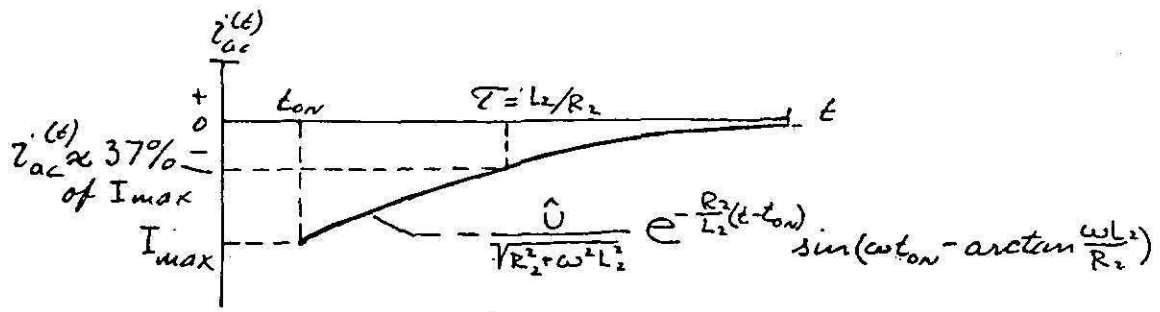

Fig. 5

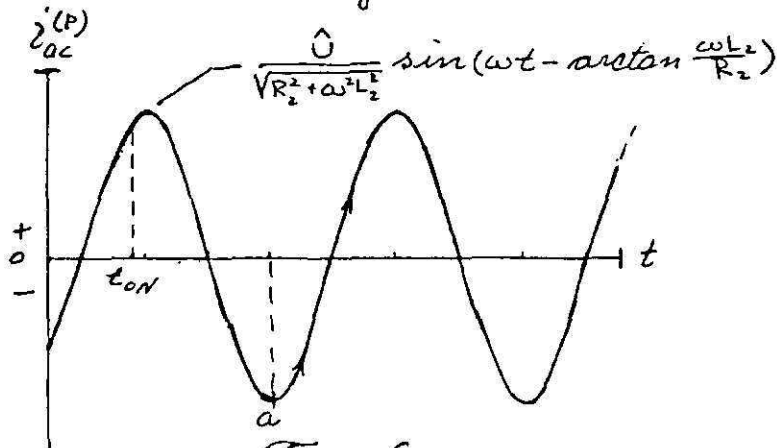

Fig. 6

The sum  $i_{ac}^{(E)} + i_{ac}^{(P)}$  which is the true ac-current in the coil\* is shown in fig. 7.

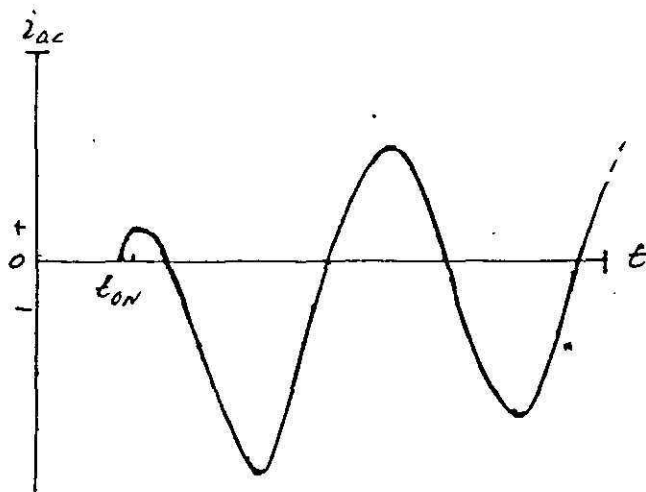

Fig. 7

\* Should be winding 2.

The Magnetizing Field.

The total number of ampere turns  $IN = i_{dc} N_1 + i_{ac} N_2$  will produce a resultant magnetizing field  $\mathcal{H}_{res}$  of the form shown in fig. 8

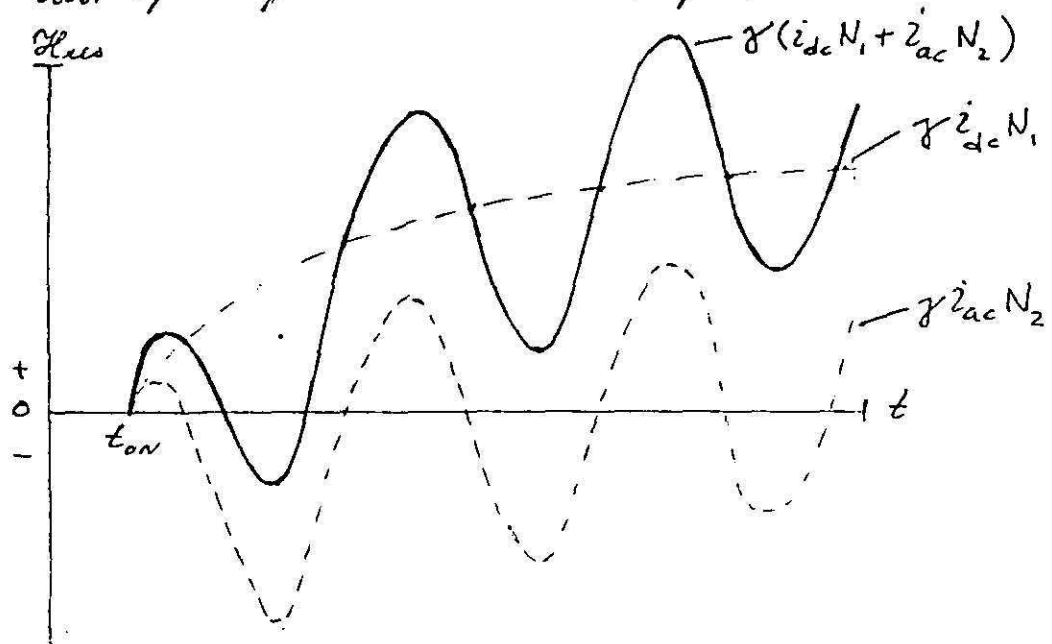

Fig. 8

Thus  $\mathcal{H}_{res} = \mathcal{H}_{ac} + \mathcal{H}_{dc} = \gamma (i_{dc} N_1 + i_{ac} N_2) \dots (5)$

Here,  $\gamma$  is a proportionality factor depending on the geometry of the magnetic circuitry. The curve form in fig. 8 represents the case when the time constant  $\tau_1 = L_1/R_1$  of winding 1 is of the same order of magnitude as the periodic time  $T = 1/f$  of the alternating current and when the number of ampere turns  $i_{dc} N_1$  in winding 1 is of the same order of magnitude as the number of ampere turns  $i_{ac} N_2$  in winding 2, i.e.

$$\frac{L_1}{R_1} \sim \frac{1}{f} \text{ and } i_{dc} N_1 \sim i_{ac} N_2$$

This case illustrates most clearly the general details of the growth of the magnetizing field.

During the magnetization process the field  $H_{res.}$  creates a magnetic induction  $B = \mu H_{res.}$  in the magnetic material with a number of minor hysteresis loops superimposed on the virgin curve, see fig. 9

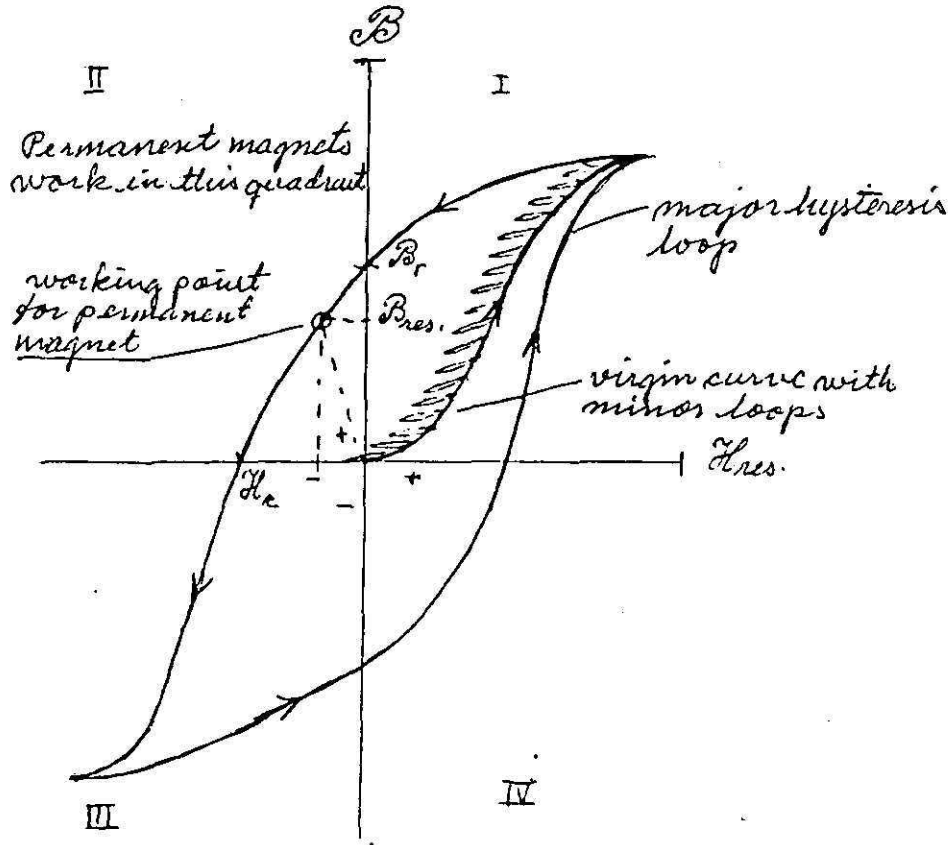

Fig. 9

Fig. 10 shows a more detailed picture of how the first few minor loops are generated. To gain an understanding of the mechanism responsible for the Leair-effect we must investigate what happens to the minor loops when the magnetizing field  $H_{res.}$  is switched off, i.e.  $H_{res.} = 0$  and the major hysteresis loop moves into the second quadrant creating a permanent magnetic induction  $B_{residual}$ , see fig. 9.

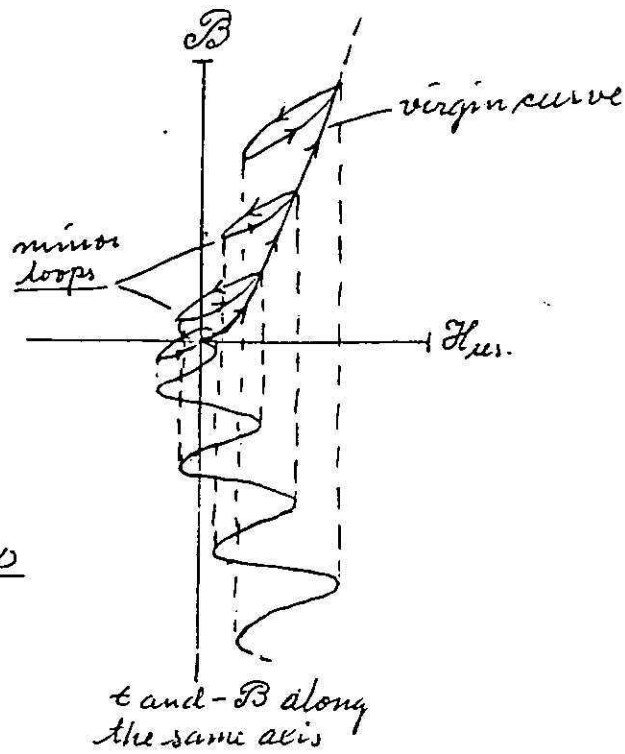
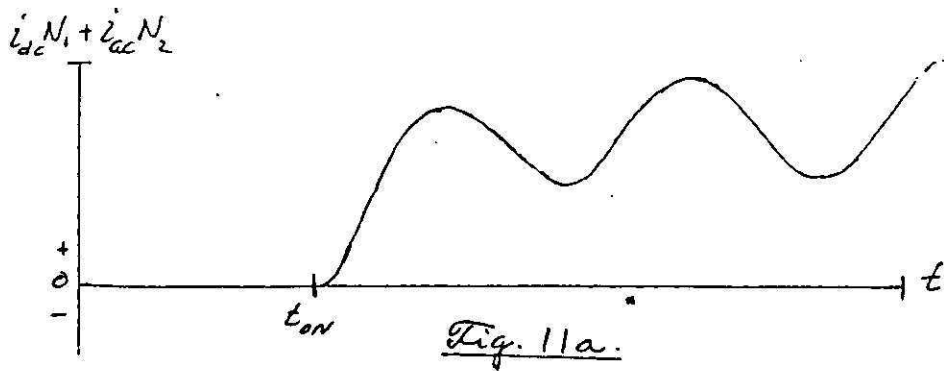

Fig. 10

According to your experience the conditions imposed on the switch should be such that the dc-current  $i_{dc}$  and the ac-current,  $i_{ac}$  are switched on simultaneously at such a time  $t = t_{on}$  that their total magnetomotive force  $i_{dc}N_1 + i_{ac}N_2$  is increasing in the positive direction and never allowed to become negative see fig. 11a.



or expressed in mathematical terms

$$i_{dc} N_1 + i_{ac} N_2 \geq 0 \dots \dots \dots (6)$$

this can be achieved by switching on the voltage sources when the steady state..... cont'd

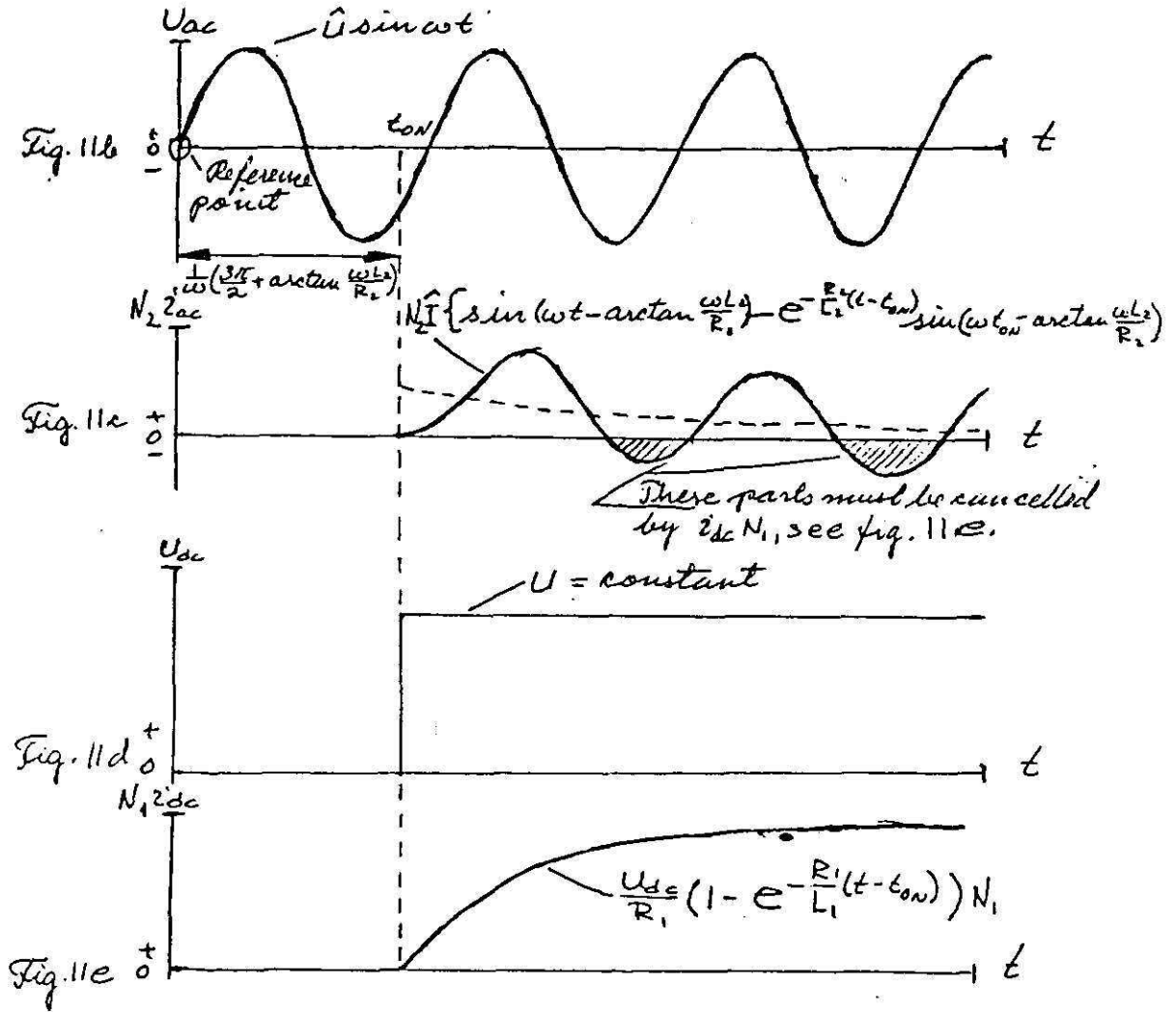

... current  $i_{ac}^{(p)}$  is beginning to grow in the positive direction, see point a in fig. 6.  
 Let us choose as a reference point the zero-crossing of the ac-voltage,  $\hat{u} \sin \omega t$ , when the voltage is increasing in the positive direction from a negative to a positive value, e.g. the origin of the co-ordinate system in fig. 11 b.  $t_{on}$  can then be expressed in terms of  $L_2$ ,  $R_2$  and  $f$ .

thus 
$$t_{on} = \frac{1}{2\pi f} \left( \frac{3\pi}{2} + \arctan \frac{2\pi f L_2}{R_2} \right) \dots (7)$$

The equation (7) is a necessary but not a sufficient condition to satisfy the inequality (6). Another, additional requirement is that the magnetomotive force,  $i_{dc}N_1$  is growing fast enough to cancel the negative parts of  $i_{ac}N_2$ , see 11c and 11e.

The Magnetizing Coils Used For Production Of "High Energy Density" Magnets.

Based upon the information you gave me I have designed a set of magnetizing coils for the runners and the plate with the following specifications.

1. General Design Data.

The coils each consists of two identical windings. Each winding contains N turns of insulated metal strips of rectangular cross-section,  $t \times w$ , see fig. 12. Insulation thickness is denoted by  $t_i$ .

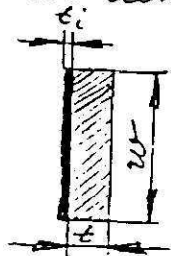

Fig. 12

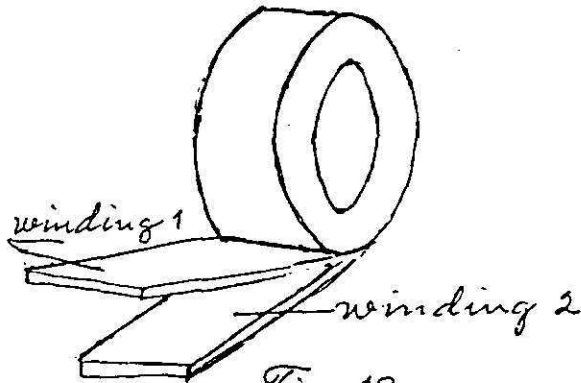

Fig. 13

The two metal strips are wound together around a cylindrical or annular body in a similar fashion as a paper insulated aluminium foil capacitor is made, see fig. 13.

Assume N turns are needed. We can then calculate the dc-resistance in each winding by using the well-known formula

$$R_{dc} = \frac{\rho \times l}{A} \dots \dots \dots (8)$$